

[®]
CHRISTY

MOIST, POWDER-LIKE AGGLOMERATING MATERIAL

Dispensers provide
uniform application of
self-adhering materials

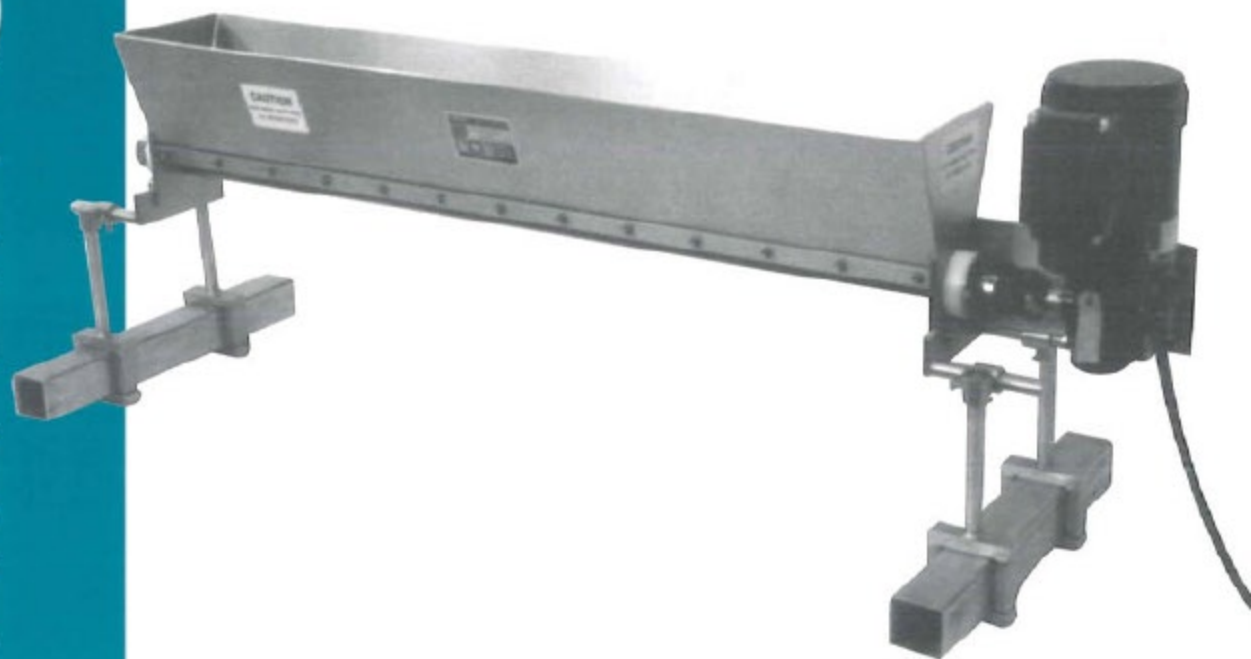

CMC
CHRISTY
MACHINE & CONVEYOR
Ingredient Dispensing Systems
Since 1953

Moist, pre-sized, powder-like materials are dispensed precisely without clogging

Applications. If moisture is present in a material, clumping and clinging develops to clog the storage hopper. Consequently, uneven coating occurs. Christy's patented Flex-Top® moist material dispenser surmounts this difficulty, allowing the user automatic, precise control of coatings such as:



parmesan cheese



moist or oily powders

Christy moist powder-like material dispensing machines, known as Flex-Top®, control the even dispensing and distributing of powder-like moist materials.

Features

- **Hopper sizes** can be customized
- Every application geared for **consistent** results
- Infinite agitator bar **speed controls** according to your needs
- Single agitator bar (selection shown) speeds cleaning and maintenance
- A selection of **mountings** to fit your operation
- A variety of **hopper bottoms** to fit the application(s) desired
- **Enclosed system** reduces contamination, maintaining sanitary conditions
- Totally enclosed 1/4 hp. DC **motors** with washdown capability are standard (stainless steel also available).....
- DC or AC **drives**



Operation. Considerably trouble-free, this dispenser involves a single rotating agitator bar with beater rods revolving within a U-shaped hopper with a choice of bottom holes for dispensing. The design prevents moist materials inserted for dispensing from clumping and clinging to the sides of the feed hopper. Each depositor system is a ready-to-run assembly.

Usage. The variable speed control, range of hopper sizes and types of hopper bottoms provide a wide range of application particle sizes and deposit rates. The steep walls of the hopper and the rotating action of the agitator bar reduce or eliminate material hanging up in the dispenser. A selection of flexible hopper bottoms, with varying aperture patterns, allows a variety of material particles to be dispensed. In addition, adjustment plates can be inserted to control the pattern of dispensing.

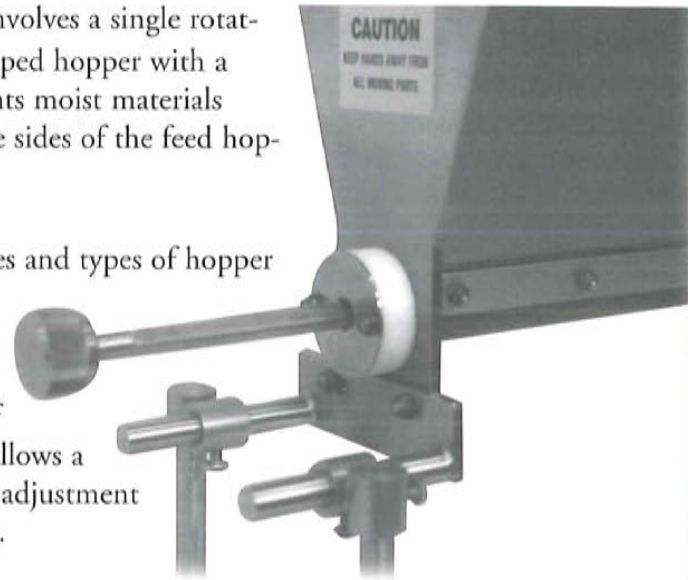

Agitator bars can be modified by varying the number and positioning of beater rods. This assembly is easily removable for cleaning or maintenance.

Hoppers can be loaded automatically or manually. Varied capacities are available to meet your needs. Aperture patterns for the flexible hopper bottoms can be machined to fit your dispensing needs. Consult with a Christy Machine representative for optimum hopper specifications for your application.

Mounting. The dispenser can be mounted above a conveyor belt (either on feet or on upper rails), and thus is readily accessible for adjustment, cleaning and necessary maintenance. The standard unit measures six inches wide by six inches high from the end view. Special sizes are available on request. A C-FRAME mount on casters allows easy movability. BRACKETS, rails and PIVOTS can be furnished for attachment to horizontal or vertical surfaces.

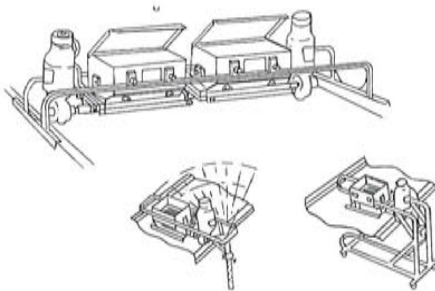

Free testing on proposed coating materials is available from Christy. After we discuss your requirements with you, we ask that you provide a 20-lb. sample for testing. Christy machines have solved many moist material dispensing problems--likely we can solve yours, too.

Optional Equipment

- Automatic start/stop controls
- Controls can be on-machine or remote; digital readouts available
- Types of motors include explosion-proof, AC, DC or pneumatic
- Conveyor systems
- Fill and/or recovery systems (for recycling)
- Product sensors
- Speed indicators
- Special controls: electromechanical, optical, counting, time delay, explosion-proof
- Dispensing pattern controls
- Custom hoppers, including insulation, water jackets and hinged lids

See our Accessories folder for all available options



C-frame configuration allows movement from one processing line to another.



Conveyor assembly is movable (Christy Moist Material Depositor shown). Many conveyor types are available.

What makes Christy the industry leader?

For half a century, Christy has solved material dispensing requirements in thousands of applications. As a result, Christy has earned a worldwide reputation for quality machines that work with reliability.

Along with this recognition, we have become experts in the top and surface coating field. Likely, we can solve *your* coating process problems, too. Call us today.

Christy manufactures machines such as these to automate your coating process:

- Dry Material Dispensing
- Moist Material Dispensing
- Fine Grain Material Dispensing
- 360° Coating
- Agglomerated Material Deposition
- Spot Deposition on Round Products
- Icing Coating
- Bottom Dusting
- Extrusion Coating

CMC
CHRISTY
MACHINE & CONVEYOR
Ingredient Dispensing Systems
Since 1953

P.O. Box 32 • 118 Birchard Avenue • Fremont, OH 43420
419 332-6451 • Fax: 419 332-8800

Made in U.S.A. • Covered by U.S. and foreign patents.
Trademarks registered. Printed in the U.S.A. • © 2000 Christy Machine Company.

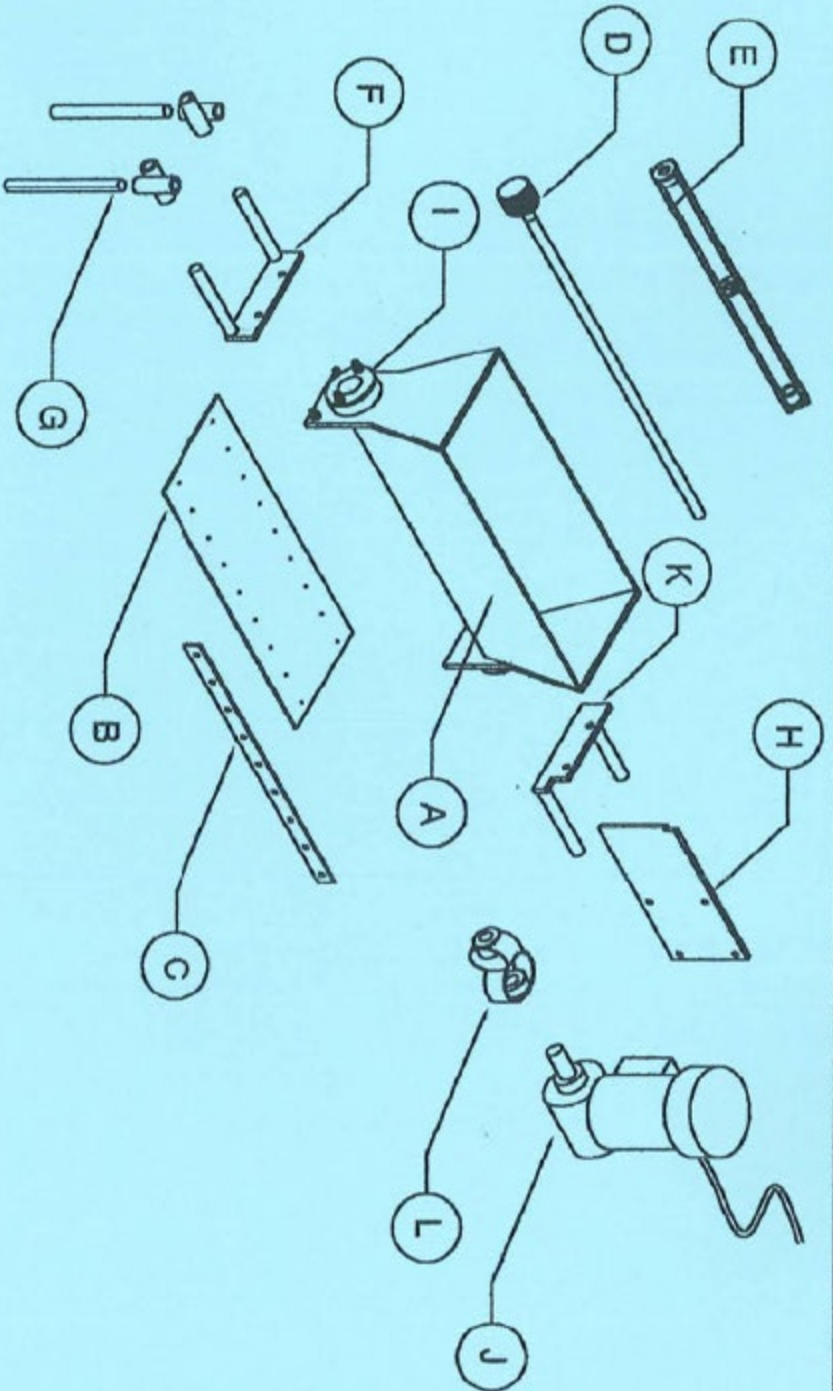

PART	DESCRIPTION	NO. REQ'D.
A	HOPPER	1
B	POLYURETHANE FLEX SYSTEM	1
C	SHEET RETAINER	2
D	DRIVE SHAFT	1
E	AGITATOR BAR WELDMENT	1
F	MOUNTING LEGS OPP. MOTOR	1
G	LEGS	4
H	MOTOR MOUNT	1
I	DELRIIN BEARING BLOCK & S.S. SUPPORT PLATE	2
J	MOTOR	1
K	MOUNTING LEGS MOTOR END	1
L	K-COUPPLING	1



CHRISTY

 MACHINE & CONVEYOR

118 BIRCHARD AVE., P.O. BOX 32
 FREMONT, OHIO 43420
 PHONE: 419-332-8451
 TOLL FREE: 888-332-8451
 RANDY FIELDING

TO ORDER PARTS
 SPECIFY MACHINE
 MODEL NUMBER
 AND SERIAL NO.