

CHRISTY SALT DISPENSING MACHINE

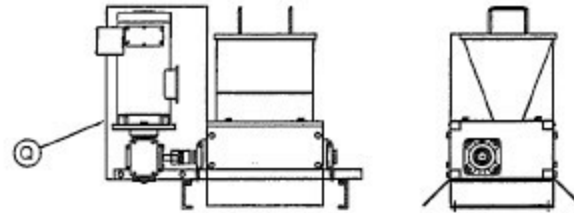
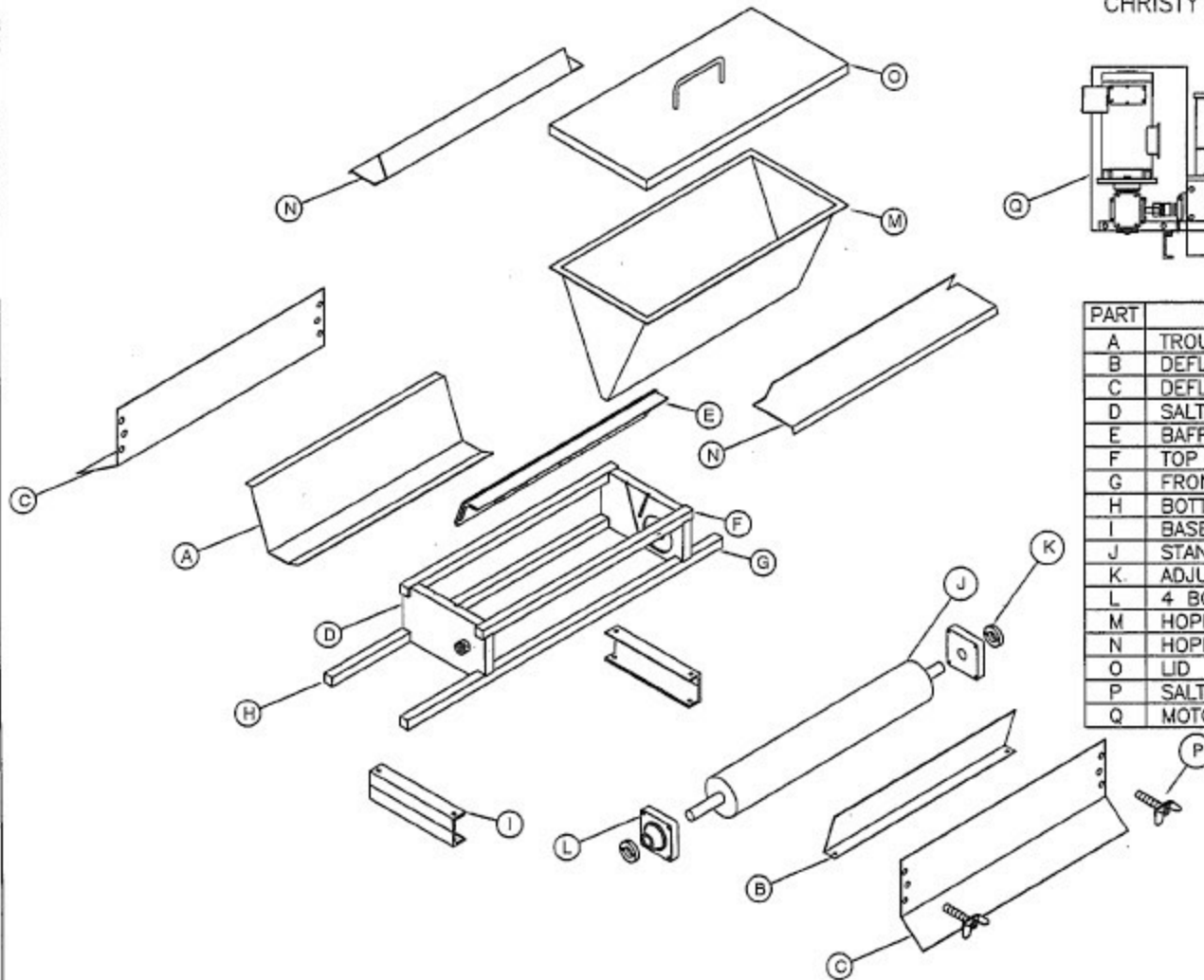

PART	DESCRIPTION	NO. REQ'D.
A	TROUGH SDM-07B	1
B	DEFLECTOR SDM-08	1
C	DEFLECTOR PLATE (FRONT AND REAR AIR) SDM-09	2
D	SALTER ENDPLATE SDM-14	2
E	BAFFLE SDM-15	1
F	TOP FRAME BAR SDM-17	2
G	FRONT BOTTOM RAIL SDM-18A	1
H	BOTTOM BACK RAIL SDM-18B	1
I	BASE ANGLE (LEG SUPPORT) SDM-21	2
J	STANDARD DISPENSING SHAFT SDM-22	1
K	ADJUSTABLE SLEEVE--1" SDM-30	2
L	4 BOLT FLANGE BEARING SDM-50	4
M	HOPPER WALLS SDM-72	1
N	HOPPER LIP (FRONT AND REAR) SDM-73	2
O	LID	1
P	SALT ROLL ASSEMBLY SDM-100	2
Q	MOTOR/REDUCER/GUARD/COUPLING/MOUNT SDM-61	

CMC
CHRISTY
MACHINE & CONVEYOR

118 BIRCHARD AVE.-P.O. BOX 82
FREMONT, OHIO 43420
PHONE: 419-332-6451
TOLL FREE: 888-332-6451
RANDY REIDING

TO ORDER PARTS
SPECIFY MACHINE
MODEL NUMBER
AND SERIAL NO.